

HMF 535-K



- power to lift.

HMF Knuckle Boom Loader 535-K

HMF loader Series 535-K in the 5 tm range

- The HMF 535-K is a loader with a hydraulic reach and lifting capacity second to none within this category.
- Equipped with manual extensions, the total reach is 11.1 metres with a lifting capacity of 270 kg.
- A simple and strong design with low tare weight, requiring minimum space on the chassis.
- Oil regeneration system in all extension cylinders, providing high working speeds on the movements of the jib extension system.
- A flexible lifting tool for hook application with the option of extra valves for rotator and clamshell bucket.
- Ideal for handling of building materials on trucks with a gross vehicle weight from 3 tonnes and over.
- Excellent close-in lifting capacities.
- Available as standard with HMF's totally integrated user-friendly RCL Safety System, which only intervenes when absolutely necessary.
- The loader series is available with the following options: radio remote control, winch, transport alarm and temperature monitoring.

Loading group B3		535-K1	535-K2	535-K3	535-K4
Load moment	tm	4.5	4.4	4.2	4.1
Hydraulic reach	m	4.9	6.4	8.0	9.6
Slewing torque	kgm	700	700	700	700
Slewing angle	°	400	400	400	400
Height above chassis	mm	1750	1750	1750	1750
Width, folded	mm	1925	1960	2050	2120
Length of loader, no extra valves	mm	530	530	530	530
Length of loader, with extra valves	mm	680	680	680	680
Stabilizer spread, standard	mm	3025	3025	3025	3025
Stabilizer spread, extra long	mm	4145	4145	4145	4145
Stabilizer spread, double extension	mm	4925	4925	4925	4925
Weight excl. stabilizers	kg	569	624	669	705
Weight of stabilizers, standard	kg	100	100	100	100
Working pressure	MPa	27	27	27	27
Pump performance	l/min	25	25	20	20
Oil capacity in base	l	23	23	23	23
Power consumption	kW	12.3	12.3	9.8	9.8
Hook height 1 m from column	m	2.2	2.1	2.0	1.9

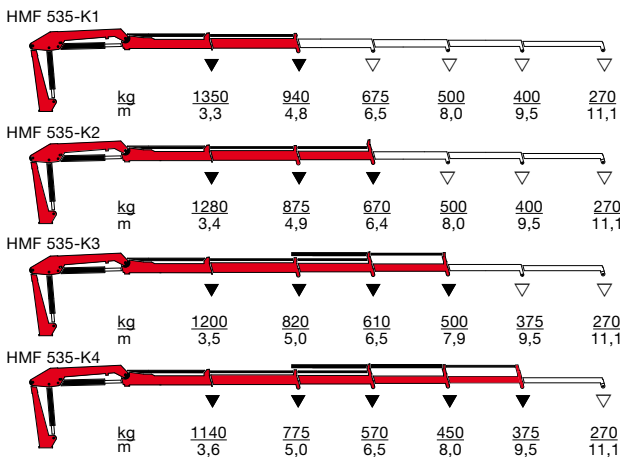
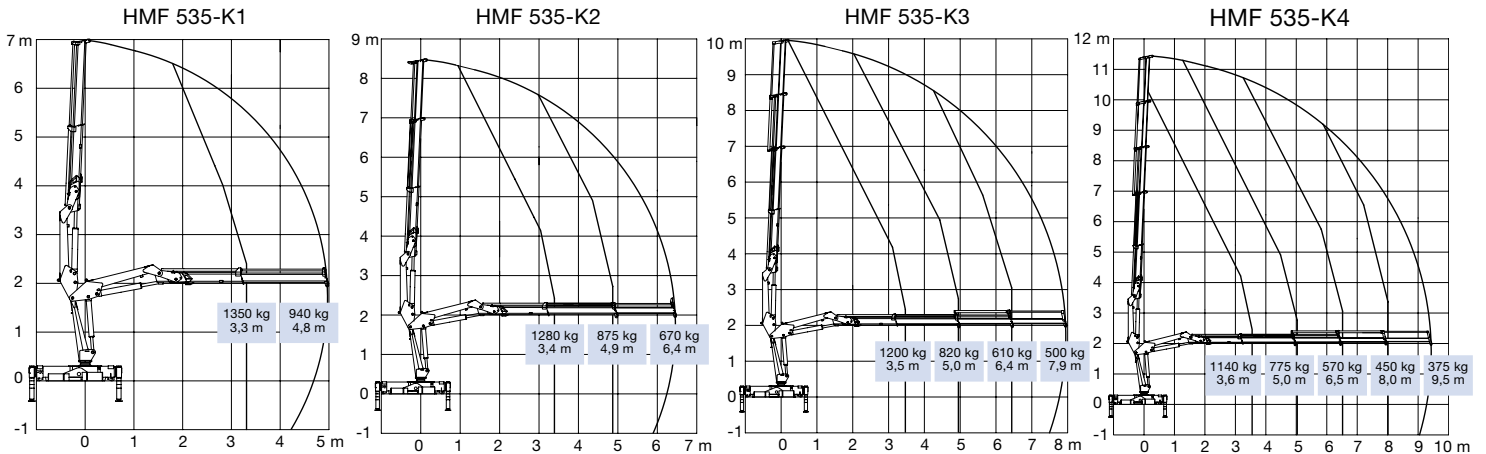

▼ Lifting capacity without manual extensions
 ▽ Lifting capacity with manual extensions

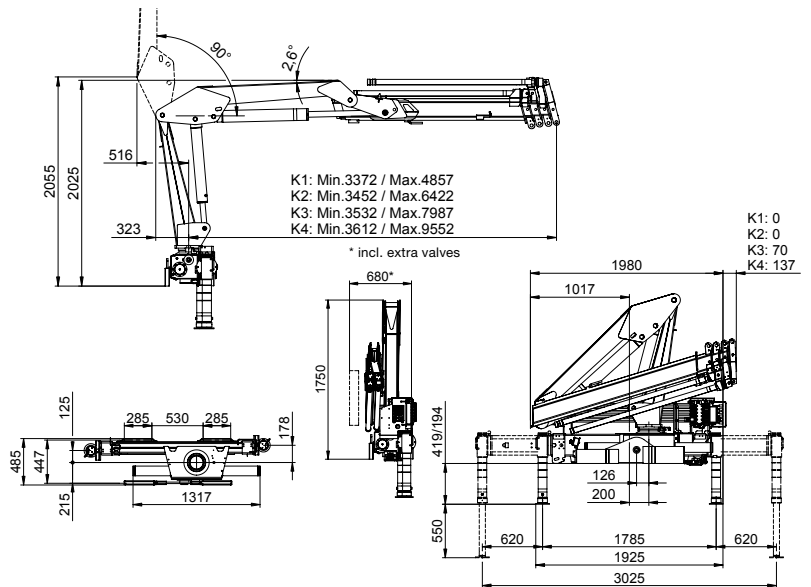

Z008362-3

We reserve the right to introduce improvements and modifications



Højbjerg Maskinfabrik A/S • Oddervej 200 • DK-8270 Højbjerg
 Tel.: +45 8627 0800 • Fax: +45 8627 0744 • info@hmf.dk

www.hmf.dk